

Real and Reactive Power Flow Control with UPFC Connected to a Transmission Line

C.S.Katariya¹
Lecturer Deptt. of
Electrical Engg
JCOET Arni Road,
Kinhi, Yavatmal.

V.G.Neve²
Lecturer Deptt. of
Electrical Engg
JCOET Arni Road,
Kinhi, Yavatmal.

A.B.Tayade³
Lecturer Deptt. of
Electrical Engg
JCOET Arni Road,
Kinhi, Yavatmal.

S.H.Rithe⁴
Lecturer Deptt. of
Electrical Engg.
JCOET Arni Road,
Kinhi, Yavatmal.

ABSTRACT

The Unified Power Flow Controller (UPFC) is the most versatile and complex power electronic equipment that has emerged for the control and optimization of power flow in electrical power transmission system. This paper presents real and reactive power flow control through a transmission line by placing UPFC at the sending end using computer simulation. When no UPFC is installed, real and reactive power through the transmission line cannot be controlled. This paper presents control and performance of UPFC intended for installation on that transmission line to control power flow. A control system which enables the UPFC to follow the changes in reference values like AC voltage, DC voltage and angle order of the series voltage source converter is simulated. In this control system, a generalized pulse width modulation technique is used to generate firing pulses for both the converters. Installing the UPFC makes it possible to control an amount of active power flowing through the line. Simulations were carried out using MATLAB and PSCAD software to validate the performance of the UPFC.

General Terms

Scheme of UPFC, shunt inverter modes, Simulation setup in PSCAD, Types of voltage controller.

Keywords

DC voltage regulation, Flexible AC Transmission Systems (FACTS), feedback control, high power PWM converters, real and reactive power, Unified Power Flow Controller (UPFC).

1. INTRODUCTION

Today's power systems are highly complex and require careful design of new devices taking into consideration the already existing equipment, especially for transmission systems in new deregulated electricity markets. This is not an easy task considering that power engineers are severely limited by economic and environmental issues. Thus, this requires a review of traditional methods and the creation of new concepts that emphasize a more efficient use of already existing power system resources without reduction in system stability and security. In the late 1980s, the Electric Power Research Institute (EPRI) introduced a new approach to solve the problem of designing and operating power systems; the proposed concept is known as Flexible AC Transmission Systems (FACTS) [1]. The two main

objectives of FACTS are to increase the transmission capacity and control power flow over designated transmission routes. The improvements in the field of power electronics have had major impact on the development of the concept itself. A new generation of FACTS controllers has emerged with the improvement of Gate Turn-Off (GTO) thyristor, ratings (4500V to 6000V, 1000A to 6000A). These controllers are based on voltage source converters and include devices such as Static Var Compensators (SVCs), Static Synchronous Compensators (STATCOMs), Thyristor Controlled Series Compensators (TCSCs), the Static Synchronous Series Compensators (SSSCs), and the Unified Power Flow Controllers (UPFCs).

The UPFC is the most versatile and complex of the FACTS devices, combining the features of the STATCOM and the SSSC. The UPFC can provide simultaneous control of all basic power system parameters, viz., transmission voltage, impedance and phase angle. It is recognized as the most sophisticated power flow controller currently, and probably the most expensive one. In this paper, a UPFC control system that includes both the shunt converter and the series converter has been simulated. The performance of the UPFC in real and reactive power flow through the transmission line has been evaluated.

2. OPERATING PRINCIPLE OF UPFC:

The basic components of the UPFC are two voltage source inverters (VSIs) sharing a common dc storage capacitor, and connected to the power system through coupling transformers. One VSI is connected to in shunt to the transmission system via a shunt transformer, while the other one is connected in series through a series transformer. A basic UPFC functional scheme is shown in fig.1.

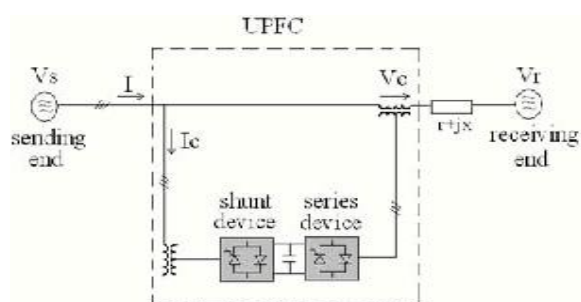

Fig.1 Basic functional scheme of UPFC

The series inverter is controlled to inject a symmetrical three phase voltage system (V_{se}), of controllable magnitude and phase angle in series with the line to control active and reactive power flows on the transmission line. So, this inverter will exchange active and reactive power with the line. The reactive power is electronically provided by the series inverter, and the active power is transmitted to the dc terminals. The shunt inverter is operated in such a way as to demand this dc terminal power (positive or negative) from the line keeping the voltage across the storage capacitor V_{dc} constant. So, the net real power absorbed from the line by the UPFC is equal only to the losses of the inverters and their transformers. The remaining capacity of the shunt inverter can be used to exchange reactive power with the line so to provide a voltage regulation at the connection point.

The two VSI's can work independently of each other by separating the dc side. So in that case, the shunt inverter is operating as a STATCOM that generates or absorbs reactive power to regulate the voltage magnitude at the connection point. Instead, the series inverter is operating as SSSC that generates or absorbs reactive power to regulate the current flow, and hence the power flow on the transmission line.

The UPFC has many possible operating modes. In particular, the shunt inverter is operating in such a way to inject a controllable current, i_{sh} , into the transmission line. The shunt inverter can be controlled in two different modes:

2.1 VAR Control Mode:

The reference input is an inductive or capacitive VAR request. The shunt inverter control translates the var reference into a corresponding shunt current request and adjusts gating of the inverter to establish the desired current. For this mode of control a feedback signal representing the dc bus voltage, V_{dc} , is also required.

2.2 Automatic Voltage Control Mode:

The shunt inverter reactive current is automatically regulated to maintain the transmission line voltage at the point of connection to a reference value. For this mode of control, voltage feedback signals are obtained from the sending end bus feeding the shunt coupling transformer. The series inverter controls the magnitude and angle of the voltage injected in series with the line to influence the power flow on the line. The actual value of the injected voltage can be obtained in several ways.

2.3 Direct Voltage Injection Mode:

The reference inputs are directly the magnitude and phase angle of the series voltage.

2.4 Phase Angle Shifter Emulation Mode:

The reference input is phase displacement between the sending end voltage and the receiving end voltage.

2.5 Line Impedance Emulation Mode:

The reference input is an impedance value to insert in series with the line impedance

2.6 Automatic Power Flow Control Mode:

The reference inputs are values of P and Q to maintain on the transmission line despite system changes.

3. SIMULATION SETUP IN PSCAD:

Fig. 2 shows the simulation model including a power system with a transmission line. The UPFC installed near the sending end effectively controls the power flow from sending end to the receiving end.

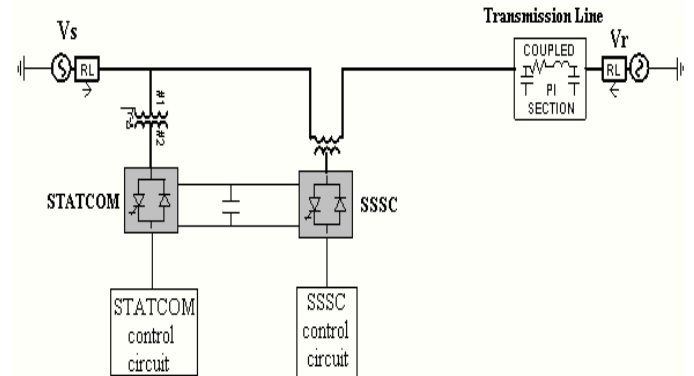

Fig. 2 Power system study model

Here, V_s and V_r are assumed to be sending and receiving-end voltages. This model assumes that sending end corresponds to a power plant while the receiving end to an electric power network, i.e., SMIB system. The receiving end voltage may not cause any phase angle change, because V_r is an infinite bus voltage. The phase angle of V_s is adjusted according to the power demand for the power plant. A phase difference of 100 between sending-end and receiving end voltages is simulated. The circuit parameters are shown in Table I. Fig.3 shows the circuit of UPFC using IGBTs.

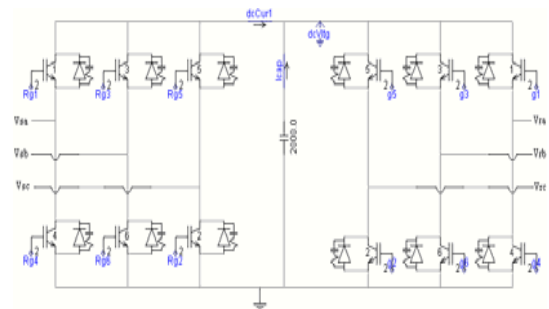

Fig.3 Circuit of UPFC using IGBTs

The main circuit of the series device (SSSC) consists of a three phase PWM inverter, the ac terminals of which are connected in series to a transmission line through three single phase transformers. The shunt device (STATCOM) consists of a three phase PWM inverter, the ac terminals of which are connected in parallel with the transmission line via a three phase star-delta transformer.

3.1 Shunt Inverter Control Circuit:

In this simulation, the shunt inverter operates in automatic voltage control mode. Fig.4 shows the DC voltage control circuit for the shunt inverter. DC link voltage is measured (V_{DCm}) & compared with the reference value (V_{DCref}), whose error is fed to PI controller to generate the shift. Similarly, AC voltage from the sending end bus feeding the shunt coupling transformer is measured in p.u, (V_{pum}) and compared with the AC voltage set point (here 1.0 p.u), whose error is fed to PI controller to generate modulation index, mi . Fig. 5 shows the AC voltage control circuit for the shunt inverter.

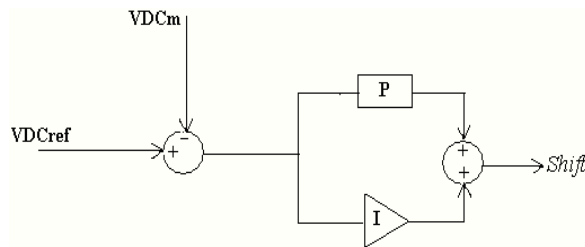

Fig. 4 STATCOM DC voltage controller

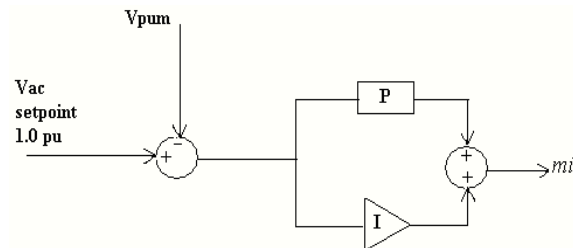

Fig. 5 STATCOM AC Voltage controller

3.1 Series Inverter Control Circuit:

In this case, the series inverter operates in the direct voltage injection mode. The series inverter simply injects voltage as per the theta order specified. Fig.6 shows the series inverter control circuit, which is an open loop phase angle controller, generates modulation index, mi and shift.

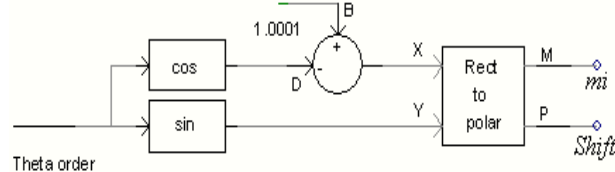

Fig. 6 Series inverter open loop phase angle controller

4. SIMULATION RESULTS

A transmission line of a simple power system with parameters as given in Table I is considered. UPFC is placed in series with the transmission line at the sending end. Deblock option blocks the UPFC for the first 0.1 second. Voltage, active power, reactive power and current variations in the transmission line with UPFC and without UPFC are studied and compared. The power system studied is SMIB system, when the transmission line is without UPFC, the sending-end and receiving-end voltages are 1.0 p.u as shown in fig. 7(a). When UPFC is placed across the same transmission line, the voltage regulation is

improved as per fig.7(b).

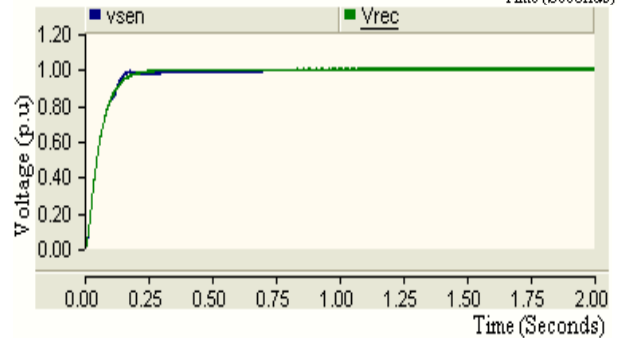
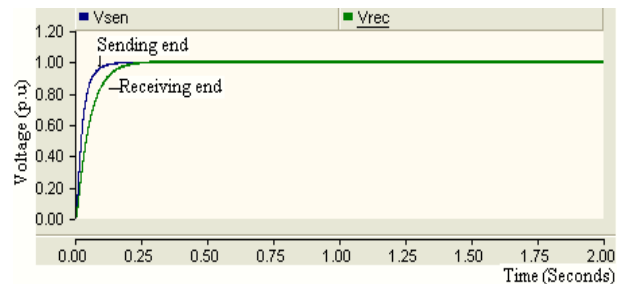

Fig. 7 Sending end and receiving end voltages (a) Without UPFC (b) With UPFC

When the transmission line is without UPFC, the real and reactive power flow can not be controlled. Fig.8(a) shows the active power through the line without UPFC. Fig.8(b) shows the active power flow through line which is controlled by UPFC. Transmission capability of the existing transmission line is highly improved with the presence of UPFC. But the difference between the sending-end real power and receiving- end real power is high in the transmission line with UPFC. This is due to the increase in transmission losses, which include losses in the both converters and coupling transformers.

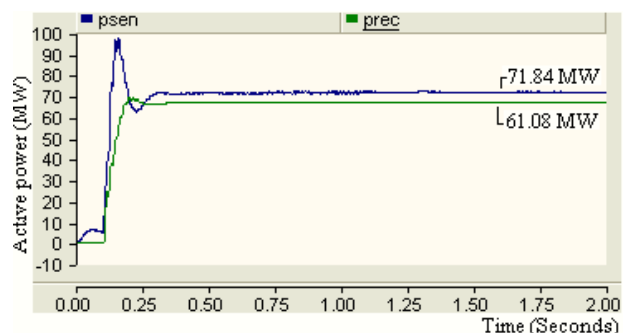
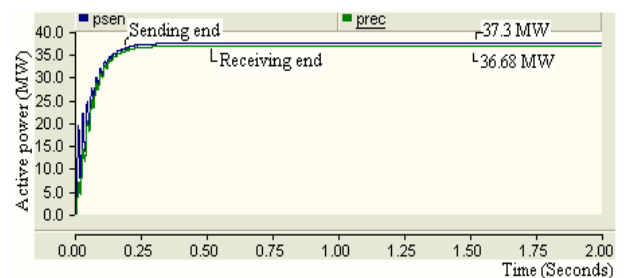

Fig. 8 sending end and receiving end active power (a) Without UPFC (b) With UPFC

The reactive power flow through the transmission line with and without UPFC is shown in fig.9. The raise in the transmission capability is noticed from the simulation results. The power transfer capability of long transmission lines is usually limited by their thermal capability. Utilizing the existing transmission line at its maximum thermal capability is possible with UPFC. The variation of current through "A" phase of a transmission line without UPFC is shown in fig. 10(a), whose peak is 0.132 kA. The current in the same phase is improved to 0.24 kA with the presence of UPFC, shown in fig.10(b)

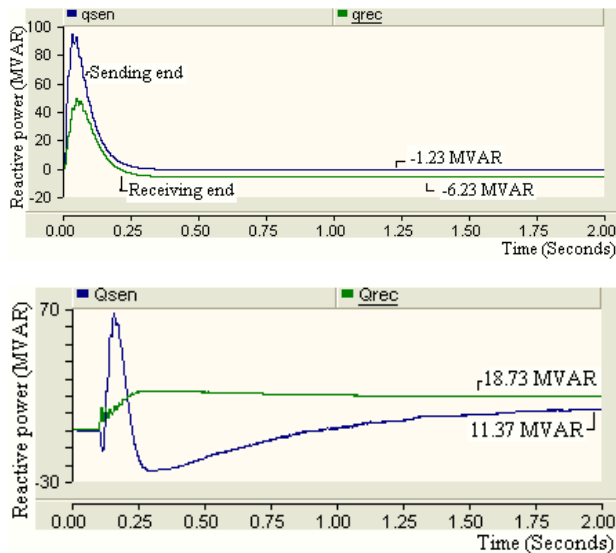

Fig.9 Sending end and receiving end reactive power
(a) Without UPFC (b) With UPFC

The series inverter injects voltage of variable magnitude and phase into the transmission line at the point of its connection, there by controlling real and reactive power flow through the line. The active power through the line is supplied by SSSC active power fig.8(b). This real power obtained from the DC source connected to its DC terminals. The shunt inverter provides the required power to the series inverter through the DC link.

5. CONCLUSIONS:

In this study, the PSCAD environment is used to simulate the model of UPFC connected to a three phase-three wire transmission system. This paper presents control and performance of UPFC intended for installation on a transmission line. A control system is simulated with shunt inverter in AC and DC voltage control mode and series inverter in open loop phase angle control mode. Simulation results show the effectiveness of UPFC in controlling real and reactive power through the line. Due to the AC voltage controller, AC voltage regulation is improved. The DC voltage controller maintains the DC link voltage to the DC voltage set point, 45 kV. This paper presents an improvement in the real and reactive power flow through the transmission line with UPFC when compared to the system without UPFC.

Table:1

Sr. no	Parameters	Value
1	Line to line voltage	230KV
2	Frequency	60Hz
3	Transmission rating	100MVA
4	Capacitance of DC link Capacitor	2000 μ F
5	DC link voltage	45KV
6	Length of the transmission line	500KM
7	Resistance of the line	32 $\mu\Omega$ /m
8	Inductive reactance of the line	388.3 $\mu\Omega$ /m
9	Capacitive reactance of the line	241.1 M-m mho

6. REFERENCES

- [1] N. G. Hingorani and L. Gyugyi, Understanding FACTS, Concepts, and Technology of Flexible AC Transmission Systems. Piscataway, N IEEEPress,2000.
- [2] L. Gyugyi, "Dynamic compensation of ac transmission lines by solid-state synchronous voltage sources," IEEE Trans. Power Del., vol. 9, no. 2, pp. 904-911, Apr. 1994.
- [3] Eskandar Gholipur and Shahrokh Saadate,"Improving of Transient Stability is Power Systems Using UPFC" IEEE Trans. Power Del., vol. 20, no. 2, pp. 1677-1682, Apr. 2005.
- [4] K. K. Sen, "SSSC—static synchronous series compensator:Theory modeling and application," IEEE Trans. Power Del., vol. 13, no. 1, pp. 241-246, Jan.1998.

AUTHORS PROFILE

Chanchal S. Katariya- received her BE degree in Electrical Engineering(E & P) from RTM Nagpur University / India. She is working towards his Master in Power Electronics & Power System from RTM Nagpur University. She has also attended various national and international Conferences. Her paper has been included in the Conference proceeding bearing the ISBN 978-81-923297-1-0. Her research is focused on Advancement in Electrical Power System..She is currently working as a Lecturer in Electrical Engineering at Jagadambha College of Engineering & Technology, Yavatmal (M.S.), INDIA, since 2010 to till date.

Vijay Gajanan Neve received the B.E. degree in Electrical Engineering and the M.E degree in Electrical Power System Engineering from the Amravati university Amravati, INDIA, in 1994 and 2000, respectively.

Currently, He is pursuing the Ph.D. degree in power quality from the same university. I'm currently working as a ASSOC. Professor in Electrical Engineering at Jagadambha College of Engineering & Technology, Yavatmal (M.S.), INDIA, since 2010 to till date. Previously I have worked as a lecturer / Sr.lecturer in Jawaharlal Darda Institute of Engineering & Technology Yavatmal (M.S.), INDIA, from 2002 to 2010.

Avantika B. Tayade- received her BE degree in Electrical Engineering(E & P) from BAMU University / India. She is working towards his Master in Power Electronics & Power System from RTM Nagpur University. She has also attended various national and international Conferences. Her research

is focused on Advancement in Power Electonics. She is currently working as a Lecturer in Electrical Engineering at Jagadambha College of Engineering & Technology, Yavatmal (M.S.), INDIA, since 2011 to till date

Supriya H. Rithe- received her BE degree in Electrical Engineering(E & P) from Mumbai University / India. She has also attended various national and international Conferences. Her research is focused on Electrical Power System. She is currently working as a Lecturer in Electrical Engineering at Jagadambha College of Engineering & Technology, Yavatmal (M.S.), INDIA, since 2012 to till date